

AT40

water quality

DEMO OUTFIT

CODE 4-3015

 **LaMotte**

Table of Contents.....

Introduction	5
Safety Information	6
Testing Hints	
Reagent Care	7
Analytical Technique	8
Model S Water Softener	
Introduction.....	9
Instructions for Use.....	10
Regeneration of Resin.....	11
Replacement of Resin	12
Total Hardness Test.....	13
Soap Demonstration	14
Precipitation Demonstration	15
pH Test	16
Iron Test	17
Optional AT Kit Test Modules	
Nitrate-Nitrogen.....	18
Free Available Chlorine.....	19
Total Residual Chlorine & Combined Chlorine	20
TDS.....	21
Replacement Parts	23
Replacement Parts	24
AT-40 Outfit Layout	25

LaMOTTE COMPANY

Helping People Solve Analytical Challenges®

PO Box 329 • Chestertown • Maryland • 21620 • USA

800-344-3100 • 410-778-3100 • Fax 410-778-6394

Visit us on the web at www.lamotte.com

Introduction.....

LaMotte Company is the leading manufacturer of specialized outfits for water treatment sales demonstration and control testing of all types of water treatment systems. The Model AT-40 is the most popular and effective sales outfit for on-site demonstration of treated water benefits. The tests are fast and simple, with visually dramatic and technically accurate results. Customize your own demo kit with the optional test modules.

This unit is designed to effectively demonstrate the differences between treated and untreated waters. "The Duo Soft" attaches to faucet and produces high quality softened water for convincing before and after demonstrations and quantitative analysis with the test equipment included.

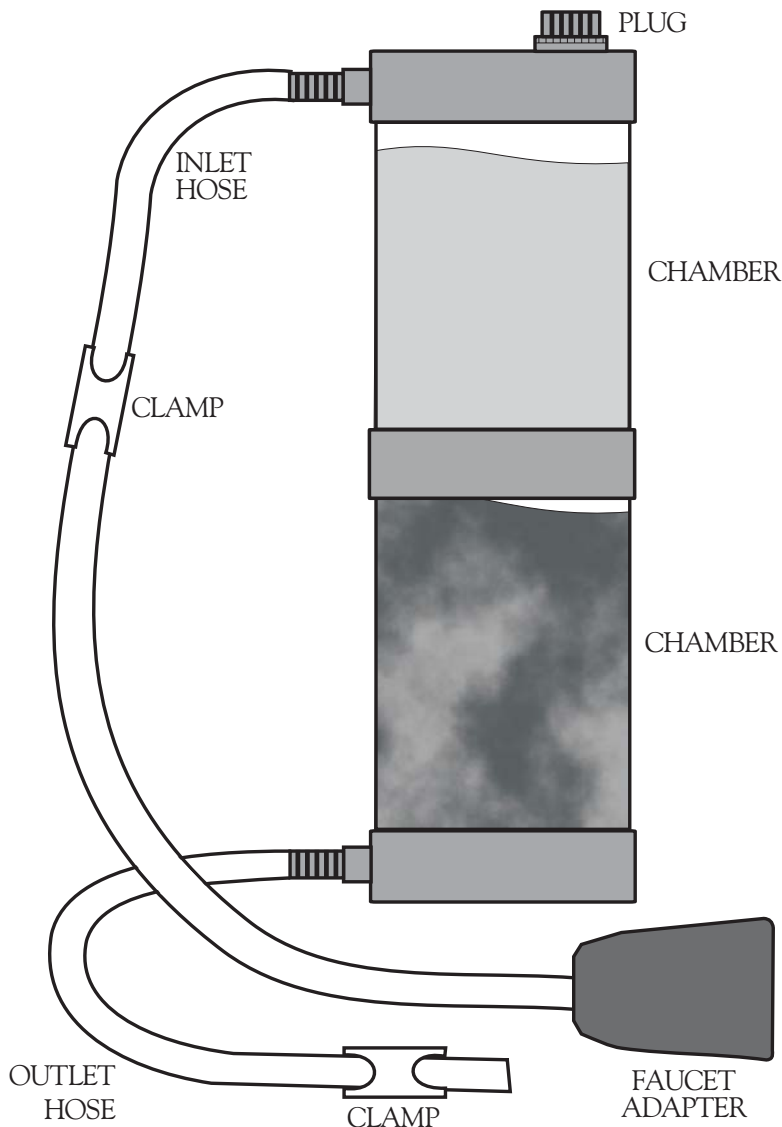

SAFETY INFORMATION

Read the instruction manual thoroughly to familiarize yourself with the test procedures before you begin. Make note of any precautions in the instructions.

Labels on each LaMotte reagent container also provide important information pertaining to the nature of the reagents. Some containers include precautionary notes or antidote information on the label.

***WARNING:** Reagents marked with an * are considered hazardous substances. To view or print a Material Safety Data Sheet (MSDS) for these reagents see MSDS CD or our web site. To obtain a printed copy, contact us by e-mail, phone or fax.

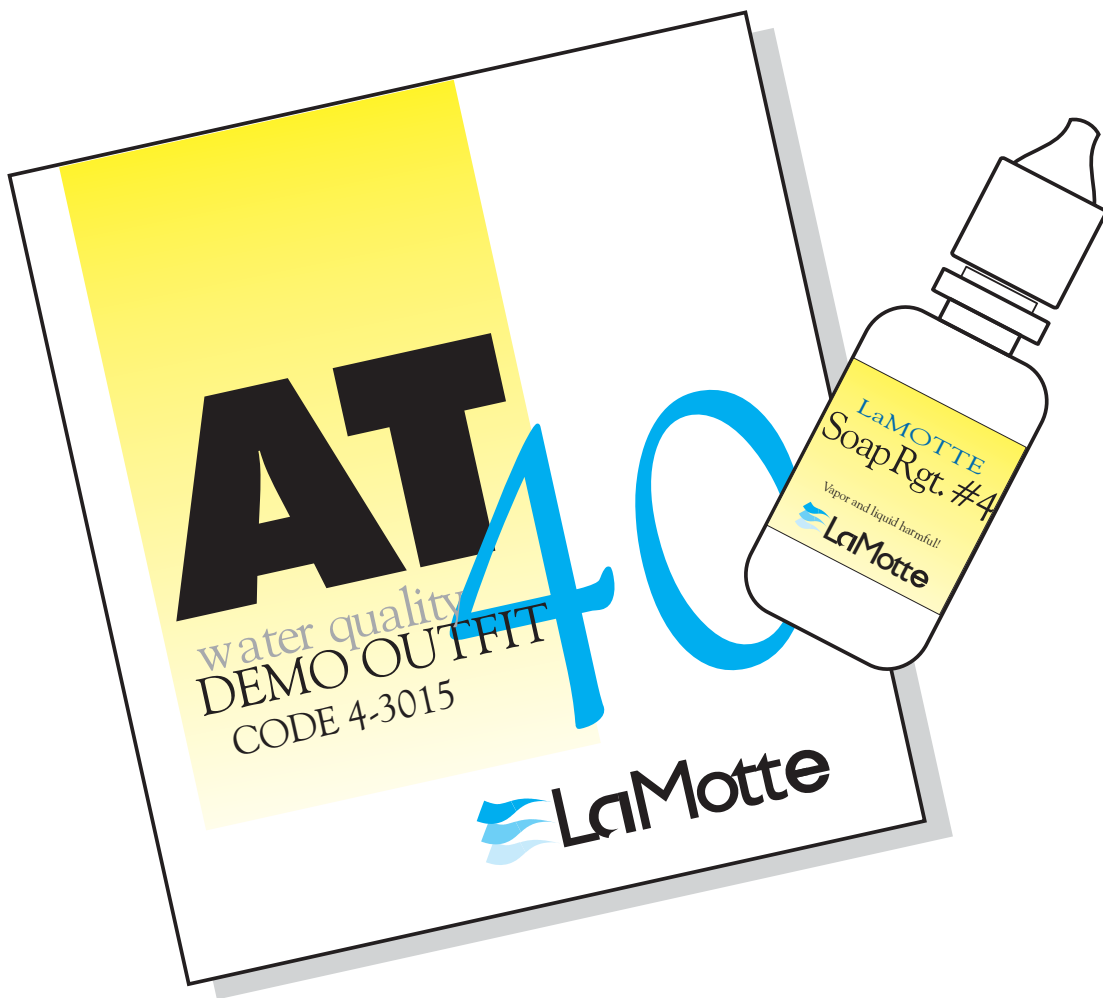

Testing Hints

1.  Tightly close all reagent containers immediately after use. Be sure not to interchange caps and pipets from different containers.

2.  Avoid prolonged exposure of equipment and reagents to direct sunlight.

3.  Protect reagents and components from extreme heat and cold.

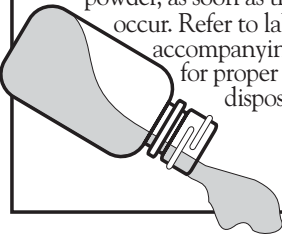
4.  Wipe up any reagent chemical spills, liquid or powder, as soon as they occur. Refer to label and accompanying MSDS for proper reagent disposal.

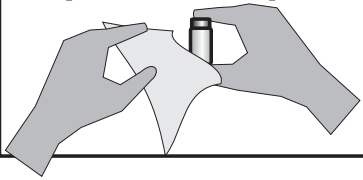
5.  Use care when dispensing or handling all reagents due to safety reasons. Some chemicals also may cause permanent stains if spilled.

ANALYTICAL TECHNIQUE

1. Clean glassware is a must for accurate results. Thoroughly rinse test tubes before and after each test. Caps and stoppers should also be cleaned after each use.
2. Use test tube caps or stoppers, not your fingers, to cover test tubes and flasks during shaking or mixing.
3. When adding sample to calibrated test tube, be sure vial is filled to the appropriate mark. The bottom of the liquid (meniscus) should be level with the desired mark. (Figure 1)
4. When dispensing reagents from bottles filled with dropper plug and cap, be sure to hold bottle vertically and gently squeeze to dispense the appropriate number of uniform drops. (Figure 2)
5. For those reagents to be added with the screwcap pipet assemblies enclosed, remove polyseal cap on bottle and replace with the screwcap pipet.

NOTE: Place the polyseal caps back on the reagent bottles for longer periods of storage. Be sure that both pipet assemblies and polyseal caps are thoroughly cleaned before placing on bottles to avoid contamination.

6. When dispensing reagents from pipets, hold pipet vertically to assure uniform drop size. This is extremely important when performing drop count titrations. (Figure 3)
7. To fill pipets, squeeze rubber bulb and immerse into reagent. Release bulb to fill. (Figure 4)
8. To accurately dispense powdered reagents with spoon, tap spoon on edge of reagent container to remove excess reagent. (Figure 5)
9. When performing tests that include Octa-Slide Comparators, the comparator should be positioned between the operator and non-direct sunlight. This allows the light to enter through the light-diffusing screen at the back of the comparator for optimum color comparison.

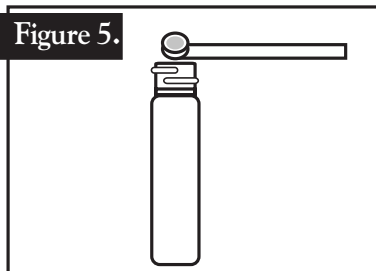
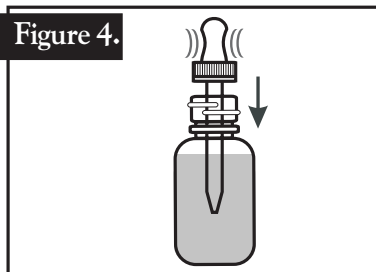
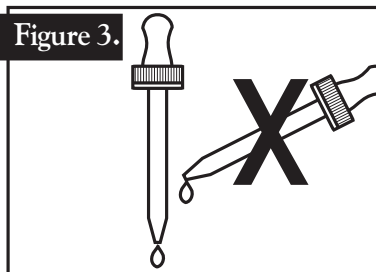
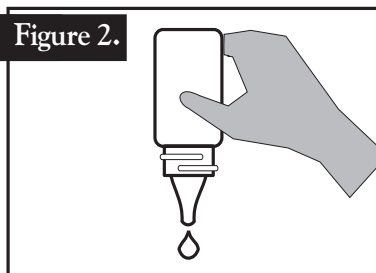
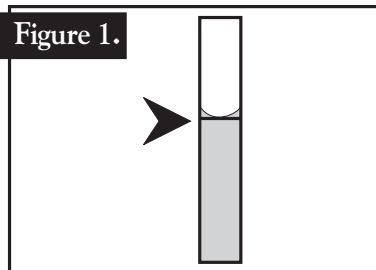

DUO-SOFT WATER SOFTENER.....

Code 0122

INTRODUCTION

The DuoSoft Water Softener is designed to produce high quality treated water. Each unit has a faucet adapter that easily connects to any standard faucet. The two chambers may be filled with the media of choice for specific problem water. Water passes through both chambers and is treated by both types of media.

READ ALL INSTRUCTIONS BEFORE USE.

NOTE: This softener **DOES NOT** yield water suitable for drinking.

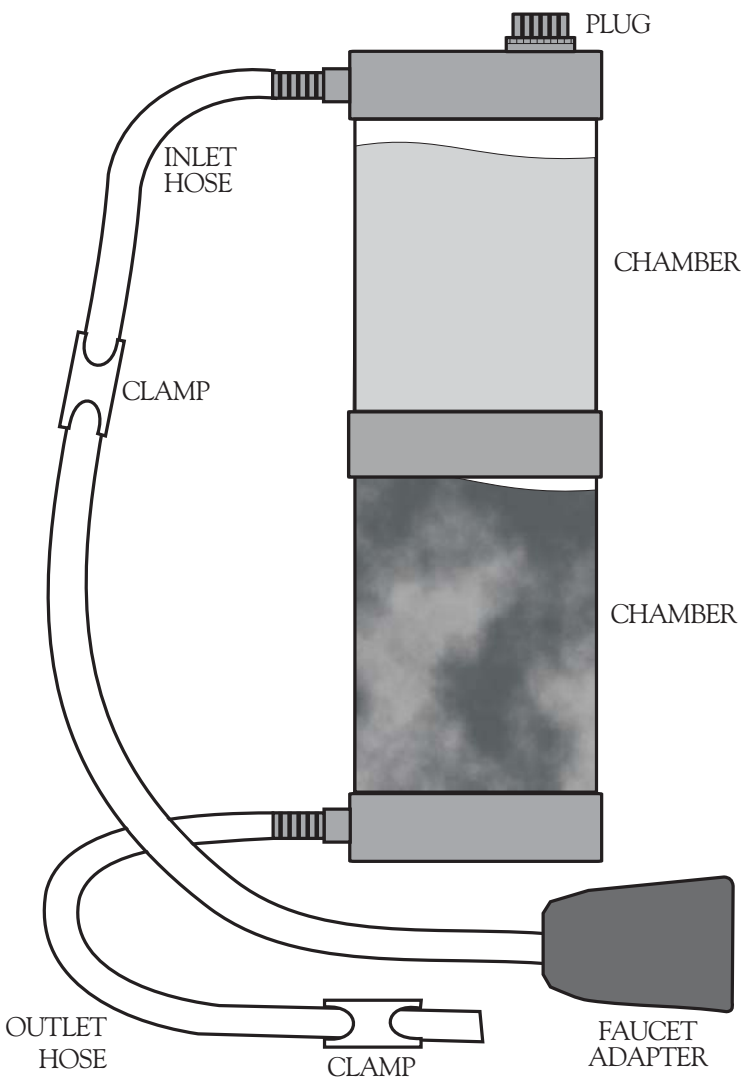

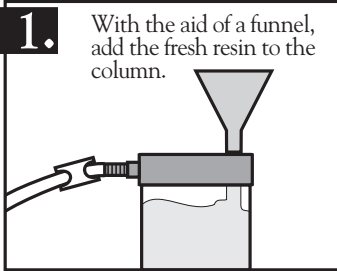
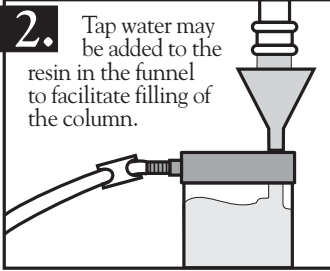
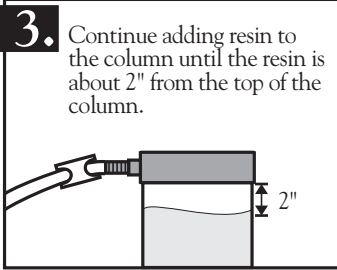
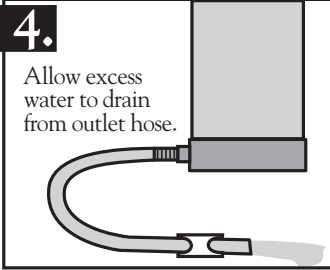
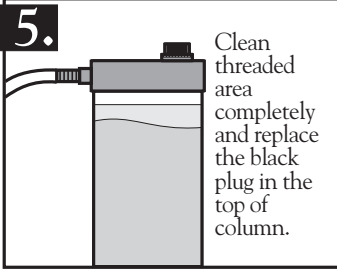
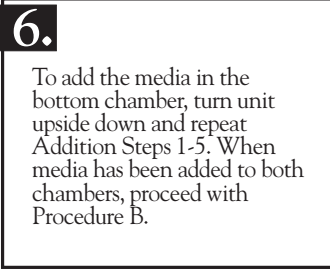

PROCEDURE A - ADDITION AND REMOVAL OF RESIN

ADDITION

- 1.** With the aid of a funnel, add the fresh resin to the column.

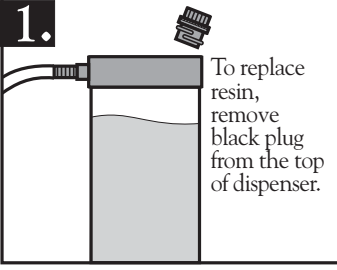
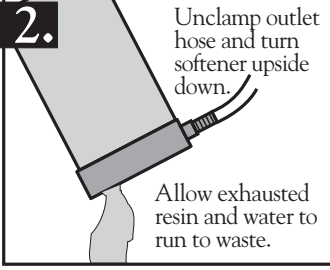
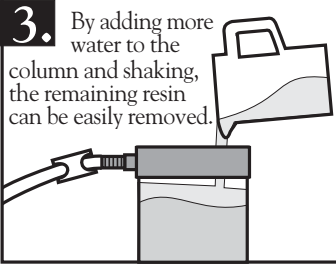
- 2.** Tap water may be added to the resin in the funnel to facilitate filling of the column.

- 3.** Continue adding resin to the column until the resin is about 2" from the top of the column.

- 4.** Allow excess water to drain from outlet hose.

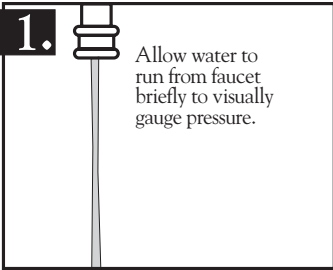
- 5.** Clean threaded area completely and replace the black plug in the top of column.

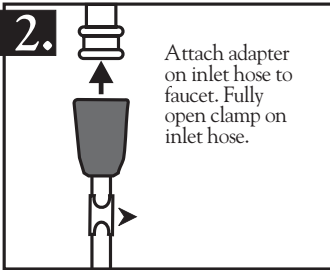
- 6.** To add the media in the bottom chamber, turn unit upside down and repeat Addition Steps 1-5. When media has been added to both chambers, proceed with Procedure B.

REMOVAL

- 1.** To replace resin, remove black plug from the top of dispenser.

- 2.** Unclamp outlet hose and turn softener upside down. Allow exhausted resin and water to run to waste.

- 3.** By adding more water to the column and shaking, the remaining resin can be easily removed.

- 4.** To remove the media in the bottom chamber, turn unit upside down and repeat Removal Steps 1-3. To add new media, follow Addition Steps 1-5 for both chambers.

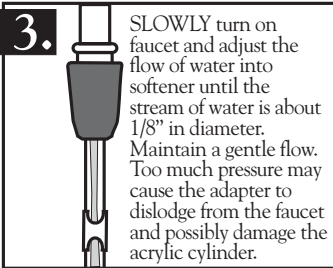
PROCEDURE B - INSTRUCTIONS FOR USE

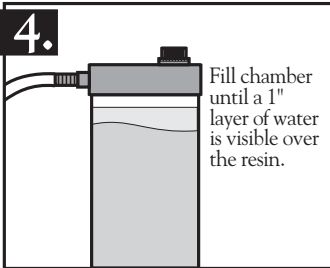
- 

1. Allow water to run from faucet briefly to visually gauge pressure.
- 

2. Attach adapter on inlet hose to faucet. Fully open clamp on inlet hose.
- 

3. SLOWLY turn on faucet and adjust the flow of water into softener until the stream of water is about 1/8" in diameter. Maintain a gentle flow. Too much pressure may cause the adapter to dislodge from the faucet and possibly damage the acrylic cylinder.
- 

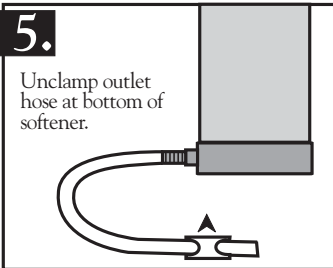
4. Fill chamber until a 1" layer of water is visible over the resin.
- 

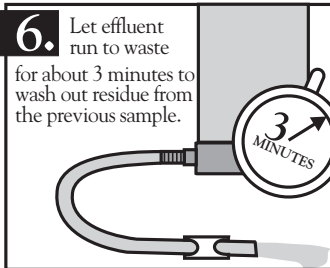
5. Unclamp outlet hose at bottom of softener.
- 

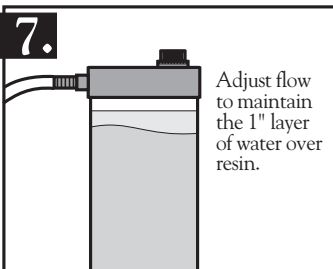
6. Let effluent run to waste for about 3 minutes to wash out residue from the previous sample.
- 

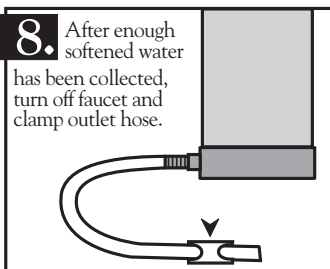
7. Adjust flow to maintain the 1" layer of water over resin.
- 

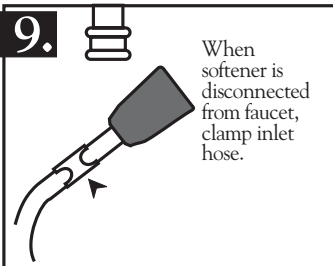
8. After enough softened water has been collected, turn off faucet and clamp outlet hose.
- 

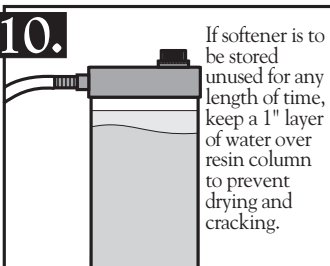
9. When softener is disconnected from faucet, clamp inlet hose.
- 

10. If softener is to be stored unused for any length of time, keep a 1" layer of water over resin column to prevent drying and cracking.

PROCEDURE C - REGENERATION OF RESIN

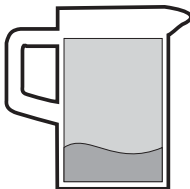
- 

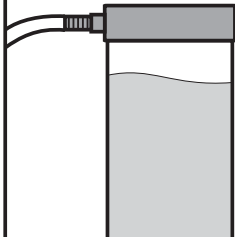
1. Prepare salt solution by dissolving about ½ pound of salt (sodium chloride) in 1 quart of water.
- 

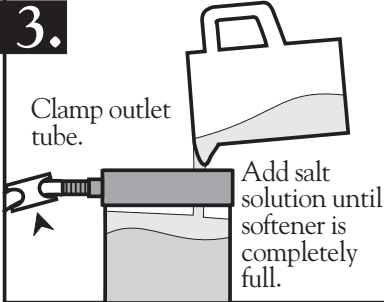
2. Remove black plug from top of softener.
- 

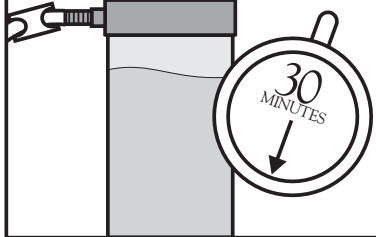
3. Clamp outlet tube.
Add salt solution until softener is completely full.
- 

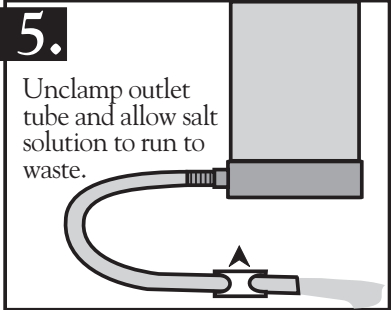
4. Allow to stand for about 30 minutes.
- 

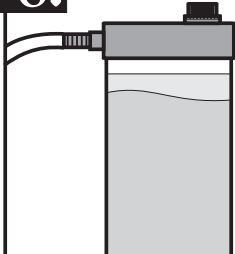
5. Unclamp outlet tube and allow salt solution to run to waste.
- 

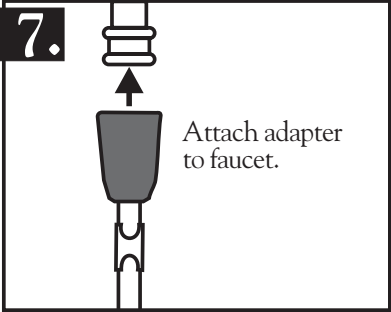
6. Clean threaded area completely and replace black plug in top of softener.
- 

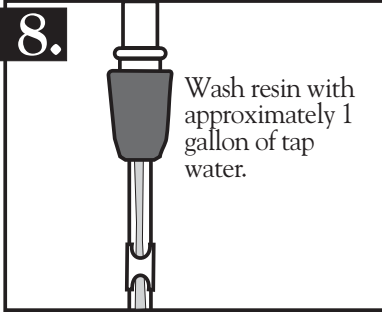
7. Attach adapter to faucet.
- 

8. Wash resin with approximately 1 gallon of tap water.
9. At this point the resin should be completely regenerated.

Total Hardness

Total Hardness of a water supply generally represents the total concentration of Calcium and Magnesium ions expressed as Calcium Carbonate (CaCO_3). Other ions may contribute, however, they are usually present in insignificant quantities. Hard waters may form scale on plumbing fixtures, consume excessive quantities of soap, and leave deposits of film on glassware, fabrics, etc. Excessive hardness may be removed by various treatment methods.

***WARNING:** Reagents marked with an * are considered hazardous substances. To view or print a Material Safety Data Sheet (MSDS) for these reagents see MSDS CD or our web site. To obtain a printed copy, contact us by e-mail, phone or fax.

TEST PROCEDURE

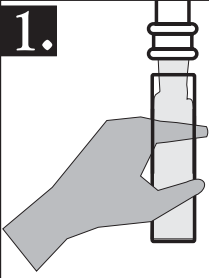
1.  Thoroughly rinse the sample tube (4488) with the water to be tested.

2.  Fill the sample tube (4488) to the desired line** with the sample water.

3.  Add 5 drops of *Hardness Reagent #5 (4483).

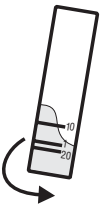
4.  Swirl to mix.

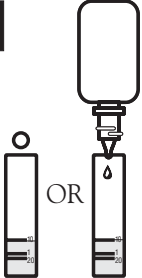
5.  Add either 1 Hardness Reagent #6 Tablet (4484) or 5 drops of *Hardness Reagent #6 (4485).

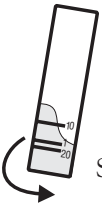
6.  Swirl to mix.

7.  Counting the number of drops and swirling between drops, add Hardness Reagent #7 (4487WT) one drop at a time until the red color changes to clear blue.

8. Multiply the number of drops used in Step 7 as follows:
Tube filled to upper line: each drop equals 10 ppm Hardness as CaCO_3
Tube filled to middle line: each drop equals 1 gpg Hardness as CaCO_3
Tube filled to lower line: each drop equals 20 ppm Hardness as CaCO_3

** When the tube is filled to upper line. Each drop of Hardness Reagent #7 is equal to 10 ppm.

When the tube is filled to middle line. Each drop of Hardness Reagent #7 is equal to 1 gpg.









When the Hardness level is over 200 ppm, fill to lower line. Each drop of Hardness Reagent #7 is equal to 20 ppm.

Soap Demonstration

Calcium and Magnesium ions present in a water supply are the principle contributors to the total hardness. Hard water tends to consume excessive quantities of soap and forms curds and deposits on glassware, fabrics, etc.

***WARNING:** Reagents marked with an * are considered hazardous substances. To view or print a Material Safety Data Sheet (MSDS) for these reagents see MSDS CD or our web site. To obtain a printed copy, contact us by e-mail, phone or fax.

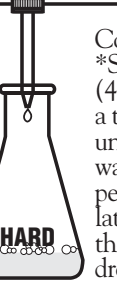
TEST PROCEDURE

<p>1.</p>  <p>Thoroughly rinse the "SOFT" water flask (0453) with softened water.</p>	<p>2.</p>  <p>Thoroughly rinse the "HARD" water flask (0452) with untreated water.</p>	<p>3.</p>  <p>Fill the "HARD" flask (0452) with untreated water until the bottom surface is covered with a layer of water about 1/2" deep.</p>
<p>4.</p>  <p>Fill the "SOFT" flask (0453) with softened water to the same level.</p>	<p>5.</p>  <p>With the pipet (0392), add 4 drops of *Soap Reagent #4 (4767) to each flask.</p>	<p>6.</p>  <p>Cap and shake the flasks.</p>
<p>7.</p>  <p>A thick lather will form in the softened water.</p>	<p>8.</p>  <p>Continue to add *Soap Reagent #4 (4767), one drop at a time, to the untreated "HARD" water, shake periodically until a lather forms. Count the number of drops added.</p>	<p>9.</p>  <p>Extremely hard water may require 30, 40, or even 60 drops of *Soap Reagent #4 to produce a lasting lather.</p>

Precipitation Demonstration.....

Again, Calcium and Magnesium ions are the major contributors to water hardness. The chemical reagents in this demonstration pull the Calcium and Magnesium ions out of solution to form a cloudy precipitate in hard water. The water that has been run through the ion exchange column has had these ions removed, therefore, the sample should remain clear.

NOTE: This portion of the AT-40 Water Quality Demo Kit is **ONLY** a visual demonstration illustrating the removal of Calcium and Magnesium ions from tap water after treatment by the ion exchange process. The results should not be interpreted beyond the intent of the demonstration.

***WARNING:** Reagents marked with an * are considered hazardous substances. To view or print a Material Safety Data Sheet (MSDS) for these reagents see MSDS CD or our web site. To obtain a printed copy, contact us by e-mail, phone or fax.

TEST PROCEDURE

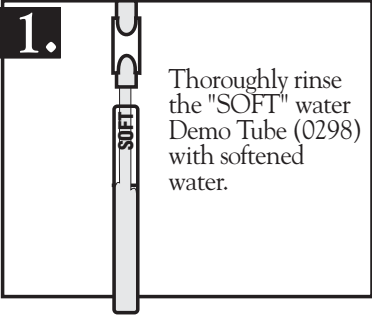
- 

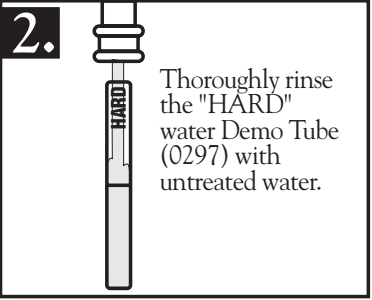
1. Thoroughly rinse the "SOFT" water Demo Tube (0298) with softened water.
- 

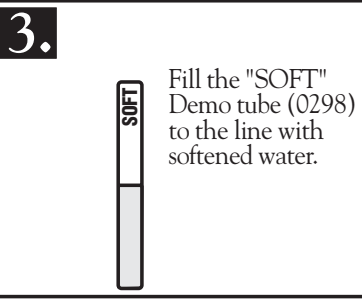
2. Thoroughly rinse the "HARD" water Demo Tube (0297) with untreated water.
- 

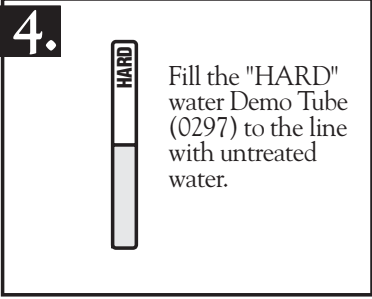
3. Fill the "SOFT" Demo tube (0298) to the line with softened water.
- 

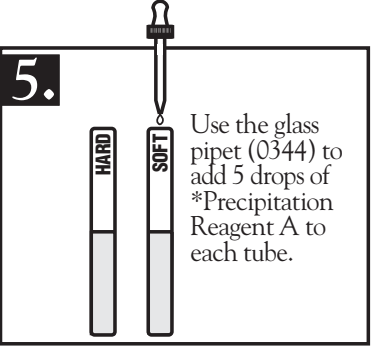
4. Fill the "HARD" water Demo Tube (0297) to the line with untreated water.
- 

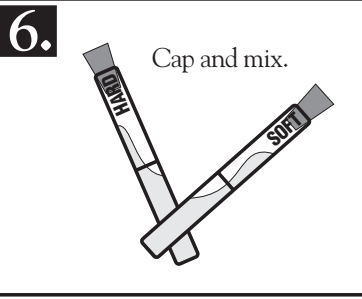
5. Use the glass pipet (0344) to add 5 drops of *Precipitation Reagent A to each tube.
- 

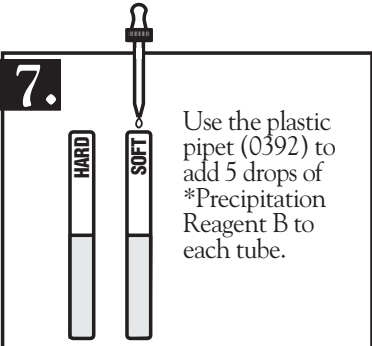
6. Cap and mix.
- 

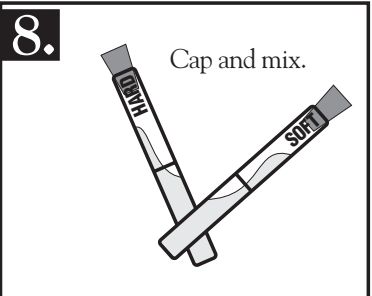
7. Use the plastic pipet (0392) to add 5 drops of *Precipitation Reagent B to each tube.
- 

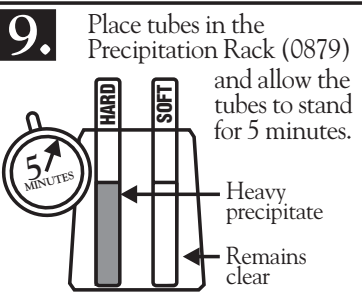
8. Cap and mix.
- 

9. Place tubes in the Precipitation Rack (0879) and allow the tubes to stand for 5 minutes.

5 MINUTES

Heavy precipitate

Remains clear

pH.....

Simply, the term pH can be considered to be an “index” of the amount of hydrogen ions present in a substance. This “index” can be used to quickly identify the acid, neutral, or alkaline (basic) nature of water. On the scale of 0.0 to 14.0, 7.0 is considered to be neutral, acidic water is less than 7.0, and basic or alkaline water is greater than 7.0. Water that is acidic in nature may cause corrosion of plumbing and equipment while alkaline water may contribute to scale buildup. Neutralization by various methods is used to correct pH for proper operation of equipment.

pH measurement may be made electronically with a pH meter or as below with a colorimetric method. The pH indicator used is a mixture of dyes that produces a specific color at various pH levels.

*WARNING: Reagents marked with an * are considered hazardous substances. To view or print a Material Safety Data Sheet (MSDS) for these reagents see MSDS CD or our web site. To obtain a printed copy, contact us by e-mail, phone or fax

Use of the Octa-Slide Viewer

The Octa-Slide Viewer should be held so non-direct light enters through the back of the viewer. With sample tube inserted at top, slide the Octa-Slide bar through the viewer and match with color standards.

TEST PROCEDURE

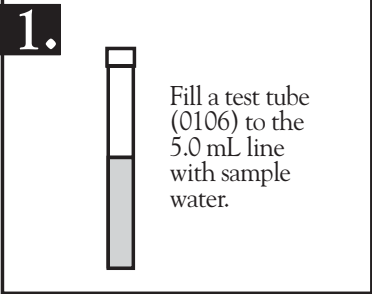
- 

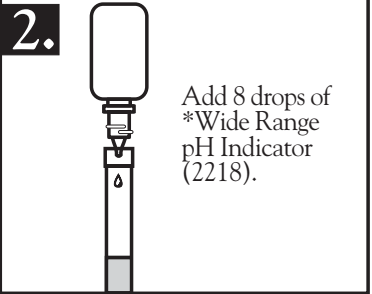
1. Fill a test tube (0106) to the 5.0 mL line with sample water.
- 

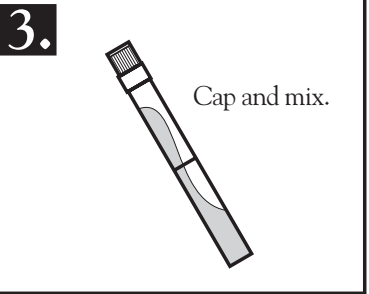
2. Add 8 drops of *Wide Range pH Indicator (2218).
- 

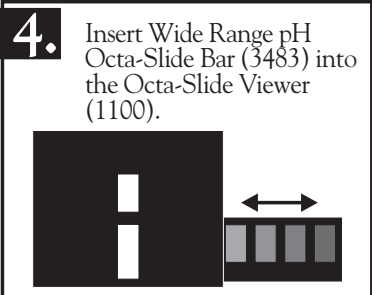
3. Cap and mix.
- 

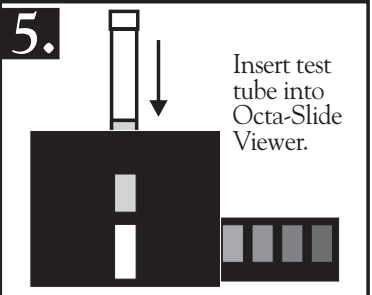
4. Insert Wide Range pH Octa-Slide Bar (3483) into the Octa-Slide Viewer (1100).
- 

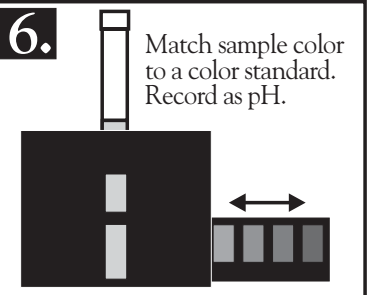
5. Insert test tube into Octa-Slide Viewer.
- 

6. Match sample color to a color standard. Record as pH.

Iron

Most natural waters contain iron, varying from trace to very large amounts in various forms. In the dissolved state (ferrous), iron water is often colorless. Upon exposure to air, or an oxidized state, ferrous iron will undergo a chemical reaction to the suspended (ferric) state causing discoloration, staining, and possibly an objectionable taste. Several methods are available for iron removal, the selection of which is dependent upon the state in which it exists.

***WARNING:** Reagents marked with an * are considered hazardous substances. To view or print a Material Safety Data Sheet (MSDS) for these reagents see MSDS CD or our web site. To obtain a printed copy, contact us by e-mail, phone or fax.

TEST PROCEDURE:

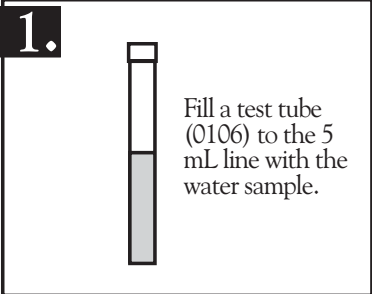
- 

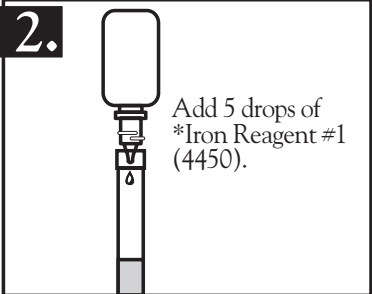
1. Fill a test tube (0106) to the 5 mL line with the water sample.
- 

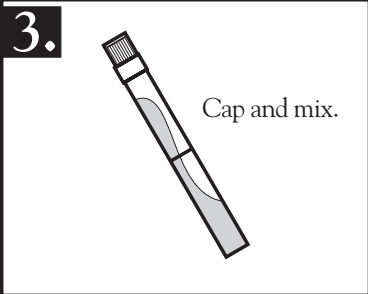
2. Add 5 drops of *Iron Reagent #1 (4450).
- 

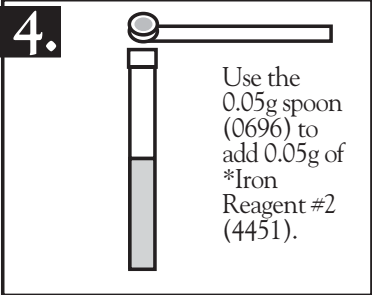
3. Cap and mix.
- 

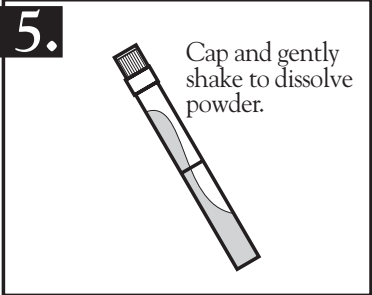
4. Use the 0.05g spoon (0696) to add 0.05g of *Iron Reagent #2 (4451).
- 

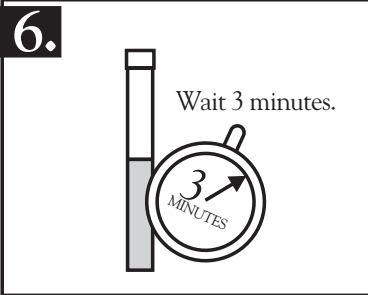
5. Cap and gently shake to dissolve powder.
- 

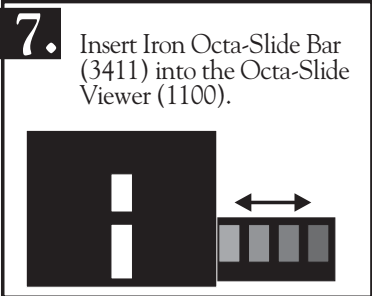
6. Wait 3 minutes.
- 

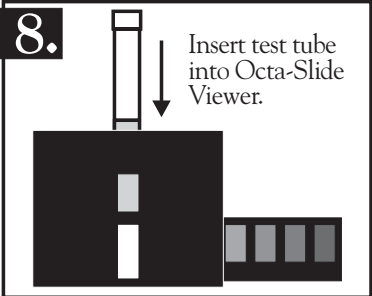
7. Insert Iron Octa-Slide Bar (3411) into the Octa-Slide Viewer (1100).
- 

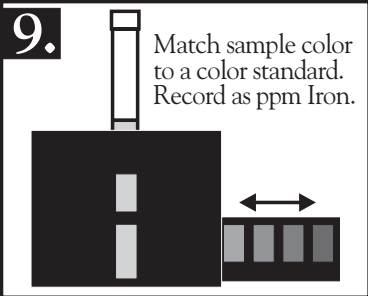
8. Insert test tube into Octa-Slide Viewer.
- 

9. Match sample color to a color standard. Record as ppm Iron.







Nitrate Nitrogen

Optional Test Module • Code 4-3004

Nitrogen is essential for plant growth, but the presence of excessive amounts in water supplies presents a major pollution problem. Nitrogen compounds may enter water as nitrates or be converted to nitrates from agricultural fertilizers, sewage, industrial and packing house wastes, drainage from livestock feeding areas, farm manures, and legumes.

*WARNING: Reagents marked with an * are considered hazardous substances. To view or print a Material Safety Data Sheet (MSDS) for these reagents see MSDS CD or our web site. To obtain a printed copy, contact us by e-mail, phone or fax.

TEST PROCEDURE

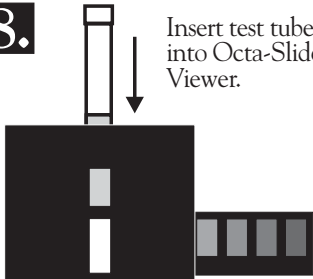
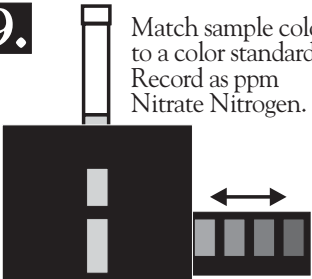
<p>1.</p>  <p>Fill a test tube (0106) to the 5 mL line with the water sample.</p>	<p>2.</p>  <p>Add one *Nitrate #1 Tablet (2799).</p>	<p>3.</p>  <p>Cap and mix until tablet disintegrates.</p>
<p>4.</p>  <p>Add one *Nitrate #2 CTA Tablet (NN-3703).</p>	<p>5.</p>  <p>Cap and mix until tablet disintegrates.</p>	<p>6.</p>  <p>Wait 5 minutes.</p>
<p>7.</p>  <p>Insert Nitrate-Nitrogen Octa-Slide Bar (3494) into the Octa-Slide Viewer (1100).</p>	<p>8.</p>  <p>Insert test tube into Octa-Slide Viewer.</p>	<p>9.</p>  <p>Match sample color to a color standard. Record as ppm Nitrate Nitrogen.</p>

To convert to Nitrate, multiply results by 4.4. Record as ppm Nitrate.

Chlorine

Optional Test Module • Code 4-3006

Water for cities and communities is usually sanitized. Even waters that come from clean sources, protected watersheds, reservoirs, and deep wells are commonly sanitized to assure safety. Chlorine is most commonly used because it is effective against a wide range of microorganisms, its cost is low, and the methods of applying it have been well developed.

***WARNING:** Reagents marked with an * are considered hazardous substances. To view or print a Material Safety Data Sheet (MSDS) for these reagents see MSDS CD or our web site. To obtain a printed copy, contact us by e-mail, phone or fax.

TEST PROCEDURE

Free Available Chlorine

- 

1. Fill a test tube (0106) to the 10 mL line with the water sample.
- 

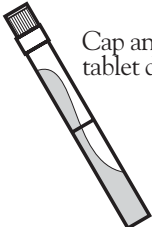
2. Add one * Chlorine DPD #1R Tablet (6999).
- 

3. Cap and mix until tablet dissolves.
- 

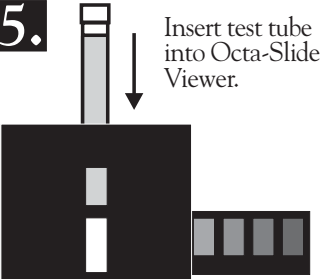
4. Insert DPD Octa-Slide Bar (3401) into the Octa-Slide Viewer (1100).
- 

5. Insert test tube into Octa-Slide Viewer.
- 

6. Match sample color to a color standard. Record as ppm Free Available Chlorine.
- 

7. Retain this sample if Total Residual and combined Chlorine are to be determined.

Total Residual Chlorine & Combined Chlorine

8.



Add one
*Chlorine DPD
#3 Tablet (6905)
to the sample
from Step 6.

9.



Cap and mix
until tablet
dissolves.

10.

Insert DPD Octa-Slide Bar
(3401) into the Octa-Slide
Viewer (1100).



11.



Insert test tube
into Octa-Slide
Viewer.



12.



Match sample color
to a color standard.
Record as ppm Total
Residual Chlorine.



TDS

Optional Test Module • Code 5-0080

BEFORE FIRST USE

Soak electrodes for a few minutes in alcohol to remove oils.

CALIBRATION (To Be Done Once a Month)

Use a calibration standard between 200 ppm and 1,900 ppm. See page 24.

- 1.** Pour 1/2" to 1" of a Calibration Standard into 2 containers, and tap or deionized water into a third container.

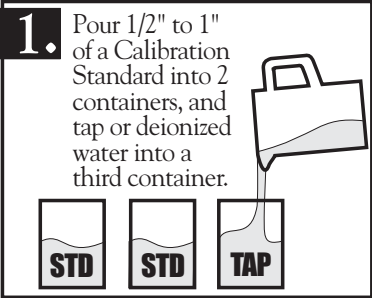

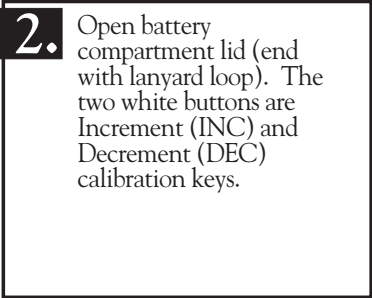
- 2.** Open battery compartment lid (end with lanyard loop). The two white buttons are Increment (INC) and Decrement (DEC) calibration keys.

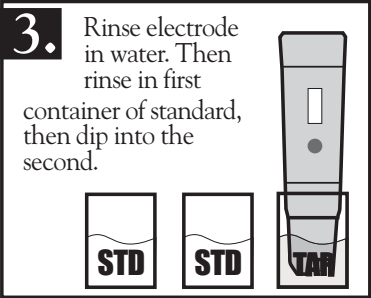
- 3.** Rinse electrode in water. Then rinse in first container of standard, then dip into the second.

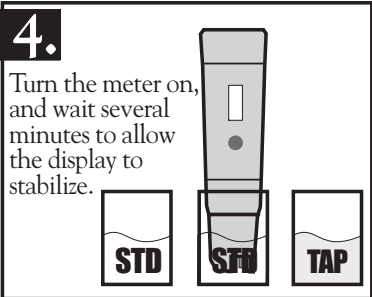
- 4.** Turn the meter on, and wait several minutes to allow the display to stabilize.

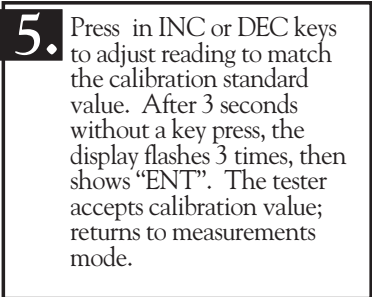
- 5.** Press in INC or DEC keys to adjust reading to match the calibration standard value. After 3 seconds without a key press, the display flashes 3 times, then shows "ENT". The tester accepts calibration value; returns to measurements mode.

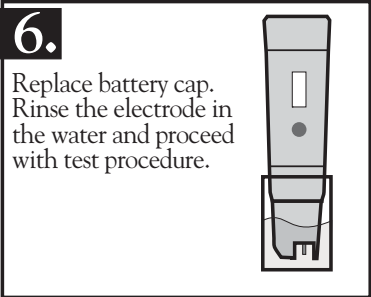
- 6.** Replace battery cap. Rinse the electrode in the water and proceed with test procedure.



SETTING THE TDS FACTOR

This tester lets you select a TDS factor of 0.4 to 1.0.

1. Open battery compartment. With meter on, press HOLD key, then press the INC key. (INC key is inside battery compartment).
2. Press the INC or DEC keys to adjust the TDS factor.
3. After 3 seconds without a key press, the display flashes 3 times, then shows "ENT". Tester accepts TDS factor and returns to measurement mode.
4. Replace battery cap.

TEST PROCEDURE:

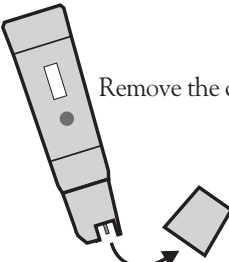
1.  Remove the cap.

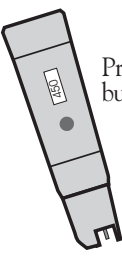
2.  Press ON/OFF button to turn on.

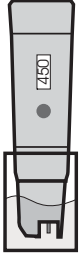
3.  Dip the electrode end into the test solution. Make sure the sensor is fully covered. Stir once. Let the reading stabilize.

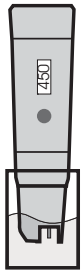
4.  Allow time for the Automatic Temperature Compensation to correct the readings for solution temperature changes.

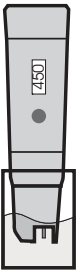
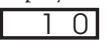
5.  Note the reading once the display stabilizes. If the solution is above the range of the TDSTestr, the display will show: 

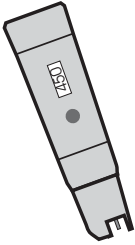
6.  Press the ON/OFF button to turn off Testr. **Note:** Testr. will automatically shut off after 8.5 minutes of nonuse.

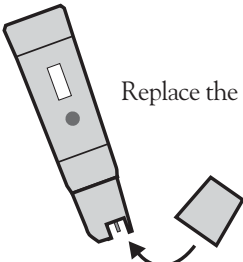
7.  Replace the cap.

Electrode Replacement: *You can replace the electrode module at the fraction of the cost of a new Testr. When the Testr. fails to calibrate or gives fluctuating readings in calibration standards, you need to change the electrode.*

1. With dry hands, grip the ribbed Testr collar with electrode facing you. Twist the collar counter clockwise. Save the ribbed Testr collar and O-ring for later use.
2. Pull the old electrode module away from the Testr.
3. Align the four tabs on the new module so they match the four slots on the Testr
4. Gently push the module onto the slots to seat in position. Push the smaller O-ring fully onto the new electrode module. Push the collar over the module and thread it onto place by firmly twisting it clockwise.

HOLD FUNCTION:

Press HOLD key to freeze display. Press HOLD again to release.

MAINTENANCE:

To improve performance, clean the stainless steel electrodes by periodically rinsing them in alcohol for 10-15 minutes. Replace all 4 batteries if the display becomes faint or disappears, or if the readings are unstable or constant. If drift is detected while electrodes are continuously exposed to solution for longer than one hour, allow electrode to fully dry off periodically.

CHANGING BATTERIES:

Open the battery compartment lid. Remove old batteries and replace with fresh ones noting polarity as shown in the battery compartment. Recalibrate Testr after battery change.

Replacement Parts

Code 4-3015 • Model AT-40

To order individual reagents or test components, use the specified code number.

CODE	DESCRIPTION	CODE	DESCRIPTION
*2218-G	*pH, Wide Range Reagent, 25 mL	1022	Duo-Soft Softener Unit
*4767-H	*Soap Reagent #4, 60 mL	0879	Precipitation Rack, acrylic
*4767-L	*Soap Reagent #4, 500 mL	0392	Pipet, plain, plastic, w/cap
*4483WT-H	*Hardness Reagent #5, 60 mL	0670	Stopper, rubber, #6, for flasks
*4483-L	*Hardness Reagent #5, 500 mL	0655	Stopper, rubber, #3, for Hardness tube
4484-J	Hardness Reagent #6 Tablets, 100	0651	Stopper, rubber, #00, for Precipitation tubes
4487WT-H	Hardness Reagent #7, 60 mL	0106	Test Tube, plastic, w/cap
*4542-H	*Precipitation Reagent A, 60 mL	1100	Octa-Slide Viewer
*4542-L	*Precipitation Reagent A, 500 mL	3483	Wide Range, pH Octa-Slide Bar, 5-10
*4543-H	*Precipitation Reagent B, 60 mL	*4450-G	*Iron Reagent #1, 25 mL
*4543-L	*Precipitation Reagent B, 500 mL	*4450-L	*Iron Reagent #1, 500 mL
0344	Pipet, glass, w/cap, 20 mm	*4451-S	*Iron Reagent #2 Powder, 4.5g
0452	Flask, 250 mL, "HARD", w/cap	0696	Spoon, 0.05g
0453	Flask, 250 mL, "SOFT", w/cap	3411	Iron Octa-Slide Bar, 0.5-10 ppm
0297	Test Tube, "HARD", 15 x 120 mm, w/cap	*WARNING: Reagents marked with an * are considered hazardous substances. To view or print a Material Safety Data Sheet (MSDS) for these reagents see MSDS CD or our web site. To obtain a printed copy, contact us by e-mail, phone or fax.	
0298	Test Tube, "SOFT", 15 x 120 mm, w/cap		
4488	Test Tube, Hardness, w/cap		
*4485WT-H	*Hardness Reagent #6, 60 mL		
*4485-L	*Hardness Reagent #6, 500 mL		

Replacement Parts

for Optional Test Modules

To order individual reagents or test components, use the specified code number.

CODE	DESCRIPTION
* 2799-H	* Nitrate #1 Tablets, 50/box
* NN-3703-H	* Nitrate #2 CTA Tablets, 50/box
3494	Nitrate-Nitrogen Octa-Slide Bar, 0–15 ppm
* 6999-H	* Chlorine DPD #1R Tablet, 50/box
* 6999-L	* Chlorine DPD #1R Tablet, 500/box
* 6905-H	* Chlorine DPD #3R Tablet, 50/box
* 6905-L	* Chlorine DPD #3R Tablet, 500/box
3401	Chlorine Octa-Slide Bar, 0.2–3.0 ppm
6354-L	Conductivity Standard, 1413 $\mu\text{mhos/cm}$ (990 ppm TDS), 500 mL

*WARNING: Reagents marked with an * are considered hazardous substances. To view or print a Material Safety Data Sheet (MSDS) for these reagents see MSDS CD or our web site. To obtain a printed copy, contact us by e-mail, phone or fax.



LaMOTTE COMPANY

Helping People Solve Analytical Challenges®

PO Box 329 • Chestertown • Maryland • 21620 • USA

800-344-3100 • 410-778-3100 • Fax 410-778-6394

Visit us on the web at www.lamotte.com